

# C15 Mowing, Verticutting & Collecting

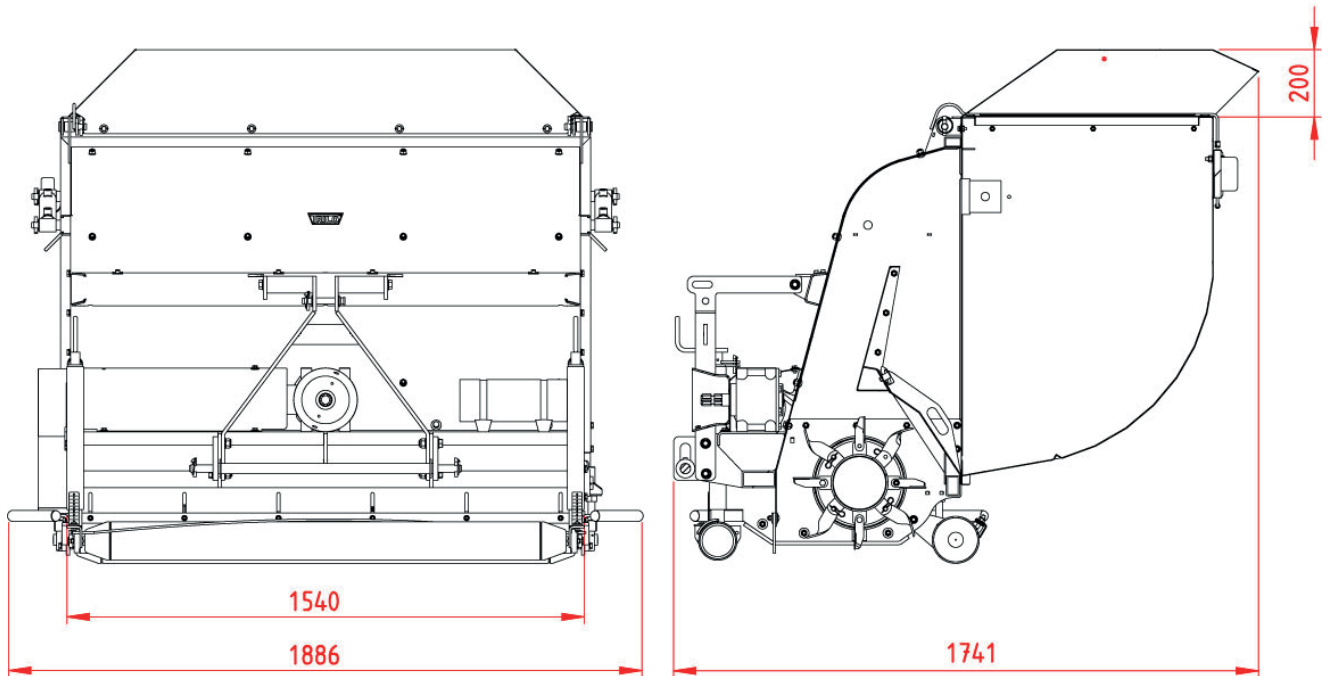

## Technical specifications

PTO output:	> 30 hp (22 Kw)	<b>Measures in mm</b>
PTO:	540 RPM	
Drive:	Power take-off	
Three point hitch:	Cat. I-II	
Required hydraulics:	120 bar - 15 l/min.	
Required hydraulic connections:	1 x single acting	
Weight:	515 kg (1135 lb)	
Measurements (LxWxH):	1,85 x 1,88 x 1,57 m (6 x 6.16 x 5.15 ft)	
Loading capacity:	1,1 m <sup>3</sup> (1.43 yd <sup>3</sup> )	
Working width:	1,50 m (4.9 ft)	
Number of knives:	48	
Diameter knives:	Rotor: Ø 455 mm (18")	
Thickness of knives:	3 mm (0.11")	
Knife distance:	26 mm (1.02")	
Front roller diameter:	Ø 114 mm (4.48")	
Working depth:	Max. 50 mm (1.96")	
Number of wind paddles:	18	
Transport dimensions:	550 kg (1212 lb) LxBxH: 200 x 180 x 164 cm (79 x 71 x 65")	

Under our policy of continuous improvement, we reserve the right to change specifications and design without prior notice. The illustrations do not necessarily show the standard version of the machine.

# C15 Mowing, Verticutting & Collecting

