

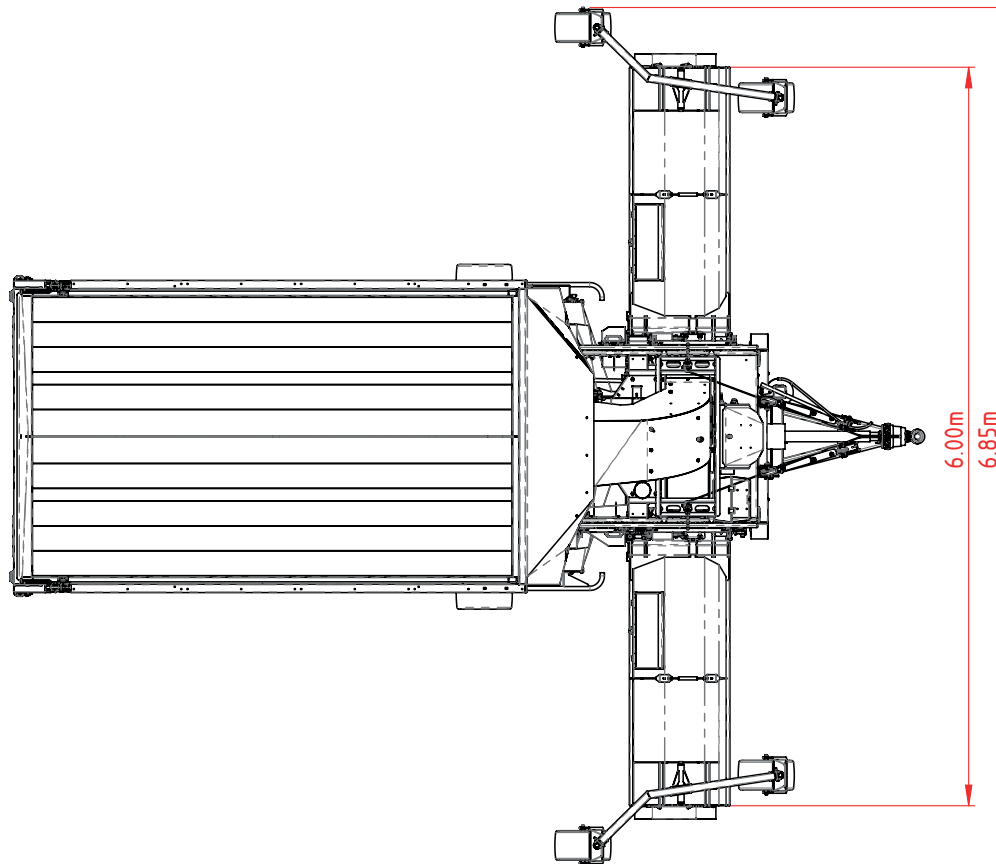

## S14 - S16 - S20 Large wide area collectors



### Technical specifications

Fan diameter:	Ø 960 mm (37.79")
Number of fan blades:	6
PTO output:	90 - 130 pk (66 - 96 KW)
PTO:	540/750/1000 RPM
Drive:	Power take-off
Required hydraulics:	180 bar - 40 l/min.
Required hydraulic connections:	2x double acting minimum
Weight:	depending on configuration
Air capacity:	390 m <sup>3</sup> /min.
Noise level:	85 dB(A)
Loading capacity:	14 - 16 - 20 m <sup>3</sup> (18 x 21 x 26 yd <sup>3</sup> )
Working width	6 m (19.68 ft)
Tyres:	505/50R17 or 435

Under our policy of continuous improvement, we reserve the right to change specifications and design without prior notice. The illustrations do not necessarily show the standard version of the machine. Not all products are available in all countries.



## S14 - S16 - S20 Large wide area collectors

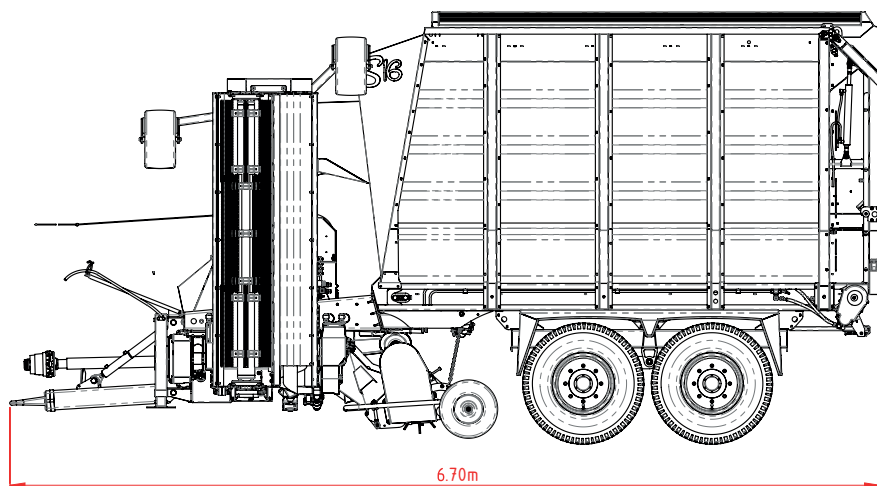
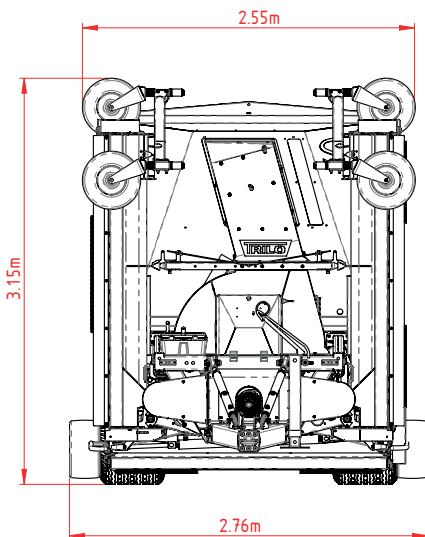
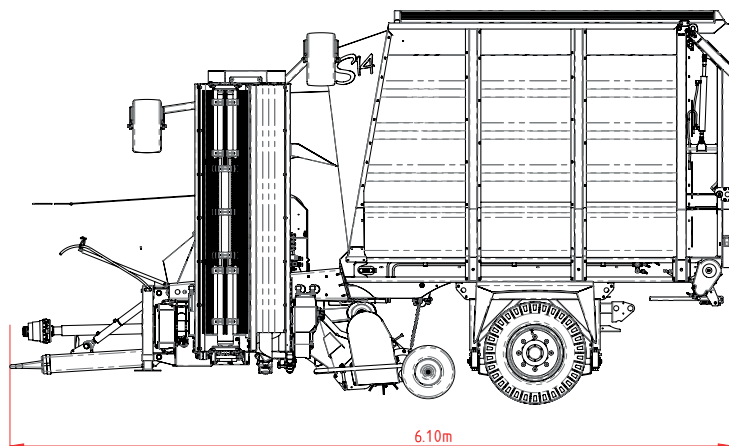
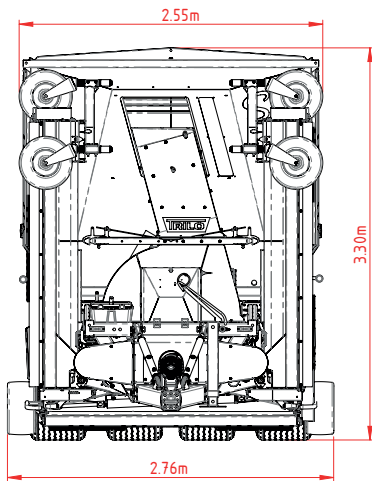

Measures are in mm



**TRILO**

## S14 - S16 - S20 Large wide area collectors

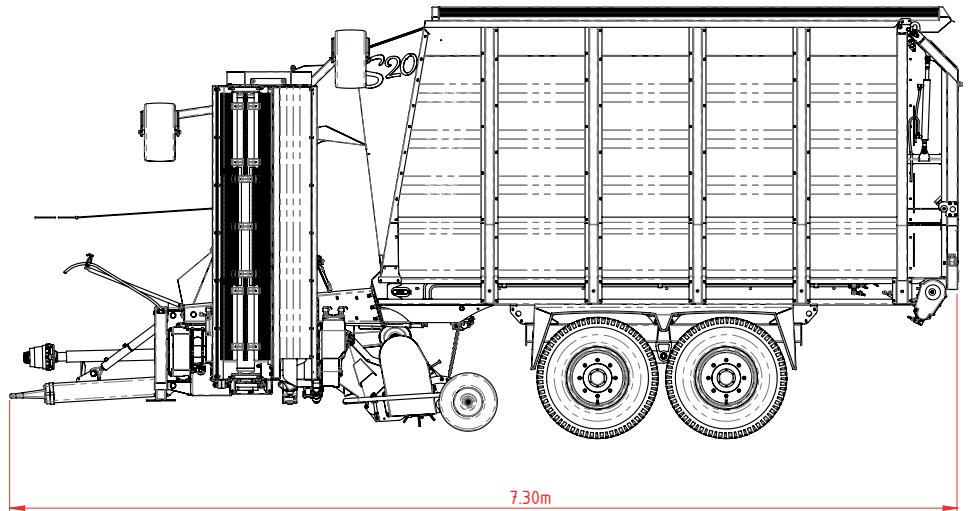
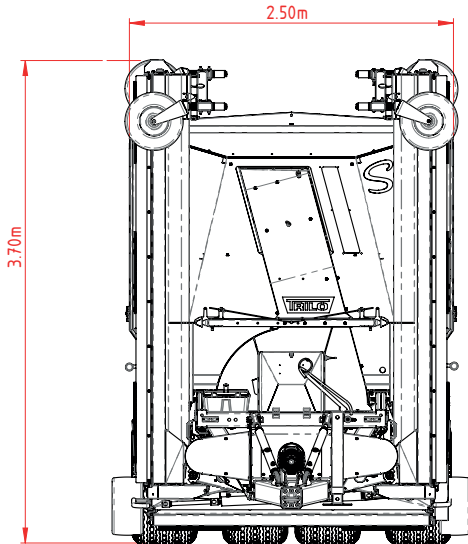

Measures are in mm

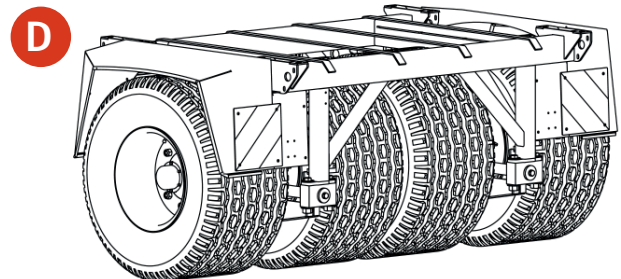
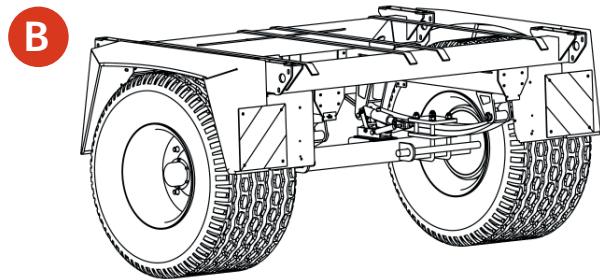
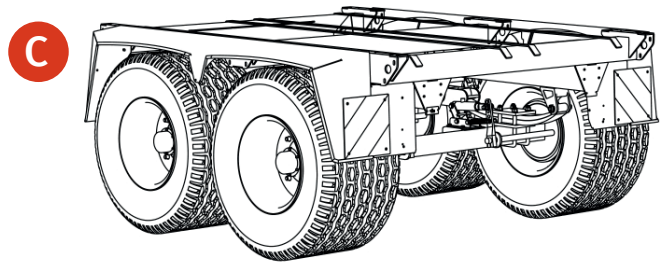
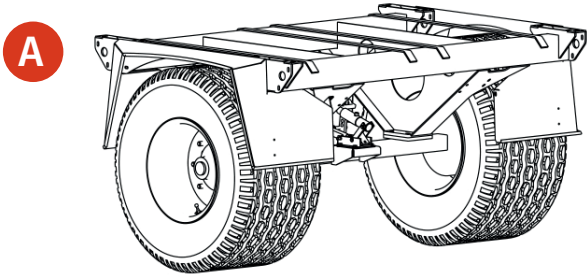

Bogie Type	A	B	C	D
Overall Width	Single 2.00 m	Single 2.30 m	Tandem 2.30 m	Pendling 2.50 m
Parabolic Spring	-	●	●	●
Dual Air Brakes	●	●	●	●
Dual Hydraulic Brakes	●	●	●	●
Single Hydraulic Brakes	●	●	●	●
Overrun Brakes	●	●	-	-
Lawn Tyres 500/50R17	●	●	●	●
Ridemax 500/50R17 Tyres	●	●	●	●
Marathon 435/50R19 Tyres	●	●	●	-
<b>Available on model:</b>				
S8	●	●	-	-
S10	●	●	●	●
S12	-	●	●	●
S14	-	●	-	●
S16	-	-	●	●
S20	-	-	●	●